

DUAL-FLEX MARINE & INDUSTRIAL ENGINE VIBRATION ISOLATORS DF-235-4 SERIES

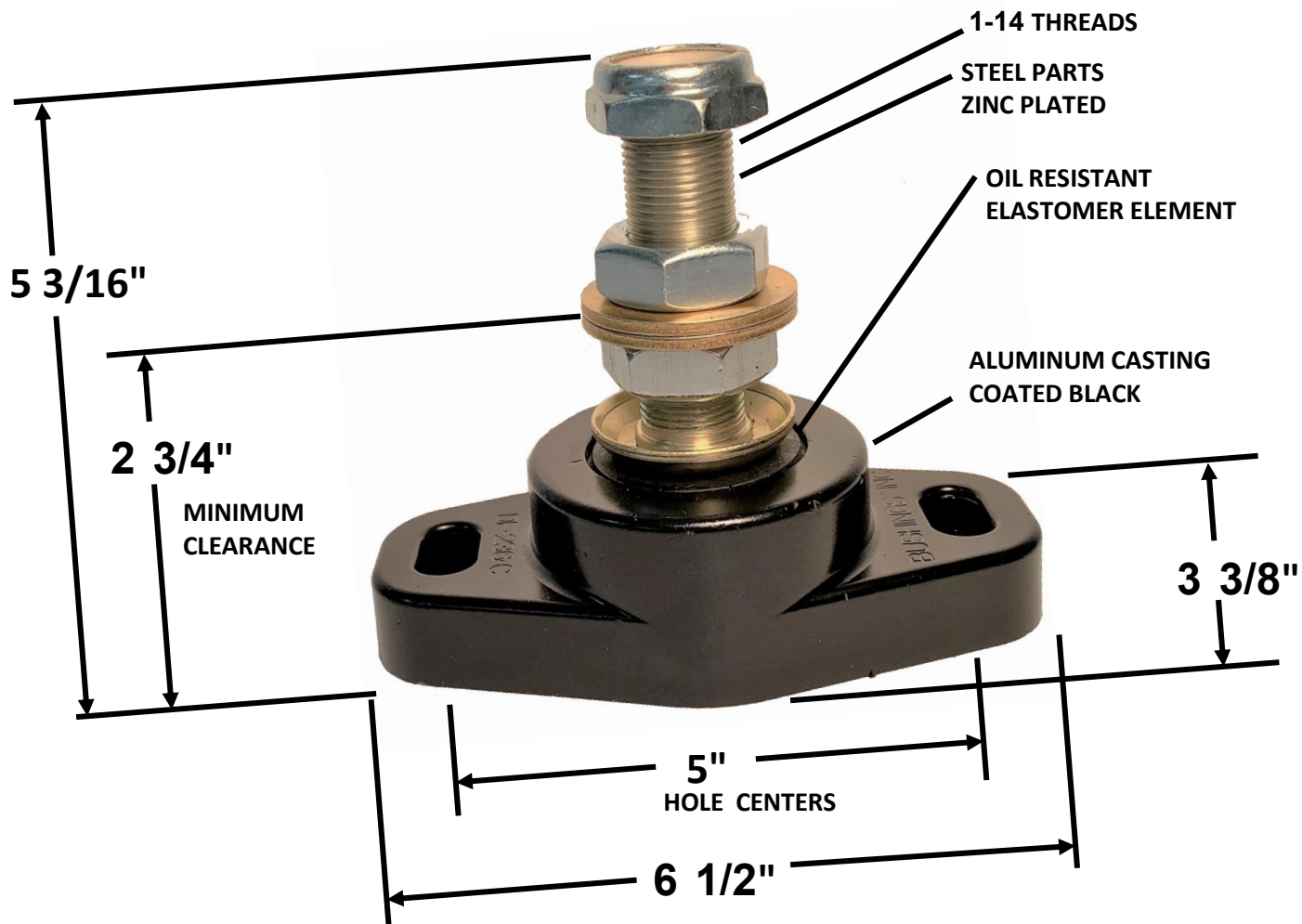

Manufactured in U.S.A.

DF-235-4-SERIES

The ("Dual Flex") DF-235-4 Series of heavy duty mountings is designed principally for diesel engines in the 700 – 2,200 lb. range. Base casting features heavy duty aluminum alloy construction, with lip incorporated in the top of the casting to resist the upward pull of the engine – coated black to resist corrosion. Durable oil and fuel resistant elastomer element. Low profile mount - requires only 2 3/4" minimum clearance from casting base to top of leveling nut. Fail safe design - bottom pad prevents excessive impact. Easy installation with 1" threaded stud for vertical height and slotted casting for horizontal

adjustment. Mounts come complete - furnished with three nuts and two washers: leveling, locking and top lock nut. Aluminum base casting with 1/2" slotted holes for 1/2" bolts or lag screws. All steel parts are zinc plated for corrosion resistance. Available in four size ratings (shown below) dependant on engine/powertrain package weight.

SUGGESTED MOUNTINGS	
ENGINE WEIGHTS	4 POINT MOUNTINGS
700 to 1100 lbs.	DF-235-4
1,100 to 1,500 lbs.	DF-236-4
1,500 to 1,800 lbs.	DF-237-4
1,800 to 2,200 lbs.	DF-238-4

The Bushings, Inc. "Dual Flex" Marine Engine Mount design provides outstanding vibration isolation control across the three (longitudinal, lateral, and vertical) fields of vibratory motion. Construction of the mount gives a soft cushioning effect under normal loads, as mount loads increase across the operating range, shear resistance grows quickly providing smooth operation with a small amount of deflection.



BUSHINGS, INC.

1967 Rochester Industrial Drive
Rochester Hills, Michigan 48309-3340
Phone:(248)650-0603 Fax:(248)650-0606
www.bushingsinc.com

