

DUAL-FLEX MARINE & INDUSTRIAL ENGINE VIBRATION ISOLATORS DF-216

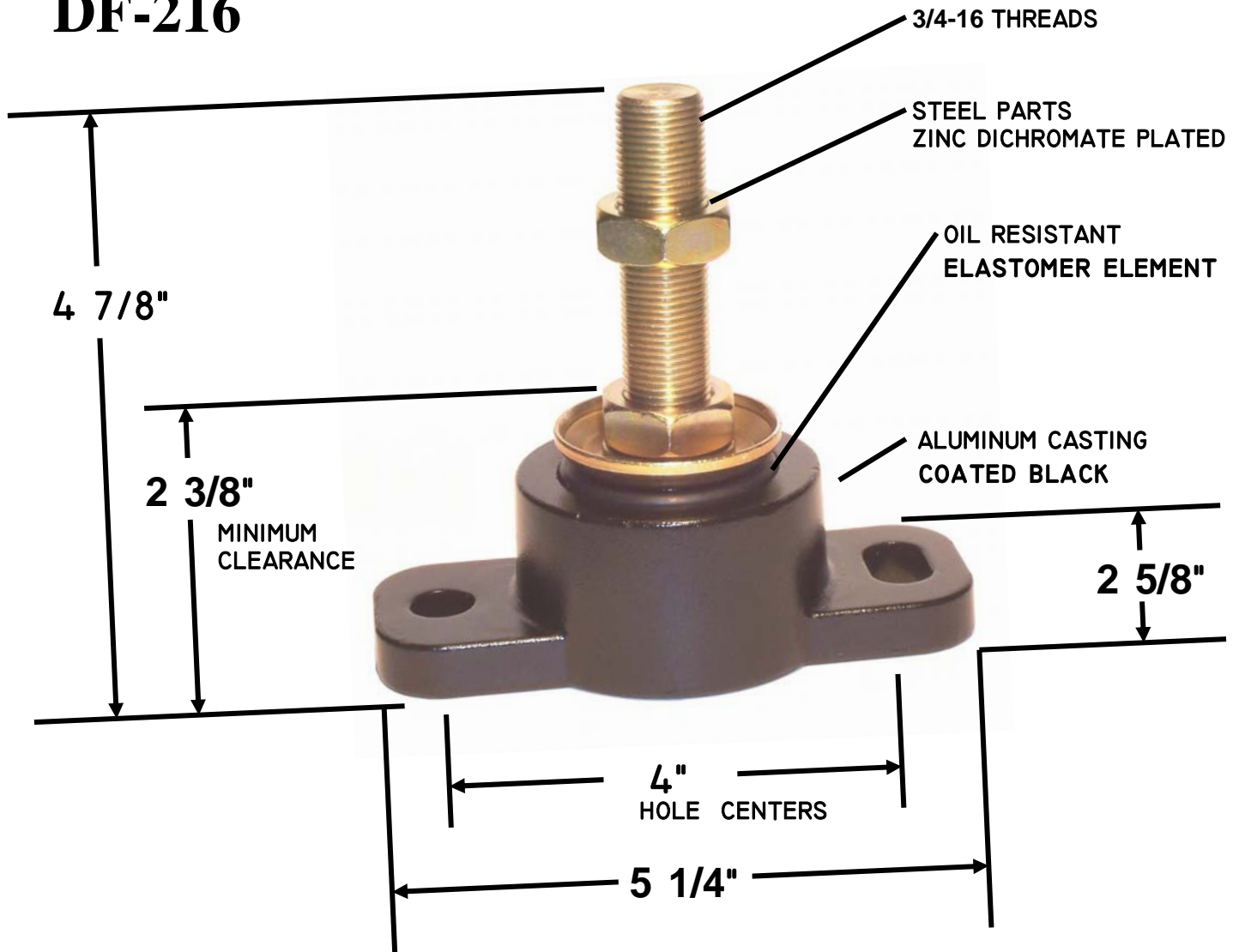

Manufactured in U.S.A.

DF-216

The ("Dual Flex") DF-216 Engine Mount recommended for all 4 and 6 cylinder, and V8 gas powered engines up to 1200 lbs. This mount features heavy duty aluminum 356 - T6 alloy construction with lip incorporated in the top of the casting to resist the upward pull of the engine - coated black to resist corrosion. Durable oil and fuel resistant elastomer element. Low profile mount - requires only 2 3/8" minimum clearance from casting base to top of leveling nut. Fail safe design -

bottom pad prevents excessive impact. Easy installation with 3/4" threaded stud for vertical height adjustment. Aluminum base cast with one 1/2" mounting hole and one slotted hole for either 1/2" bolts or lag screws on 4" centers. Mounts furnished complete with leveling, and locking nuts. All steel parts are zinc dichromate plated for corrosion resistance.

SUGGESTED MOUNTINGS

ENGINE WEIGHTS

4 POINT MOUNTINGS

up to 1200 lbs.

DF-216

The Bushings, Inc. "Dual Flex" Marine Engine Mount design provides outstanding vibration isolation control across the three (longitudinal, lateral, and vertical) fields of vibratory motion. Construction of the mount gives a soft cushioning effect under normal loads, as mount loads increase across the operating range, shear resistance grows quickly providing smooth operation with a small amount of deflection.



BUSHINGS, INC.

1967 Rochester Industrial Drive

Rochester Hills, Michigan 48309-3340

Phone:(248)650-0603 Fax:(248)650-0606

www.bushingsinc.com

